



Gas engine lubricants for power generation applications



HDAX



texacolubricants.com/HDAX



▲ **Texaco® HDAX Path of Innovation**

HDAX®

We have developed and produced gas engine oil products since 1962.

Since 2009, Europe has fully transitioned to the Texaco HDAX product line.

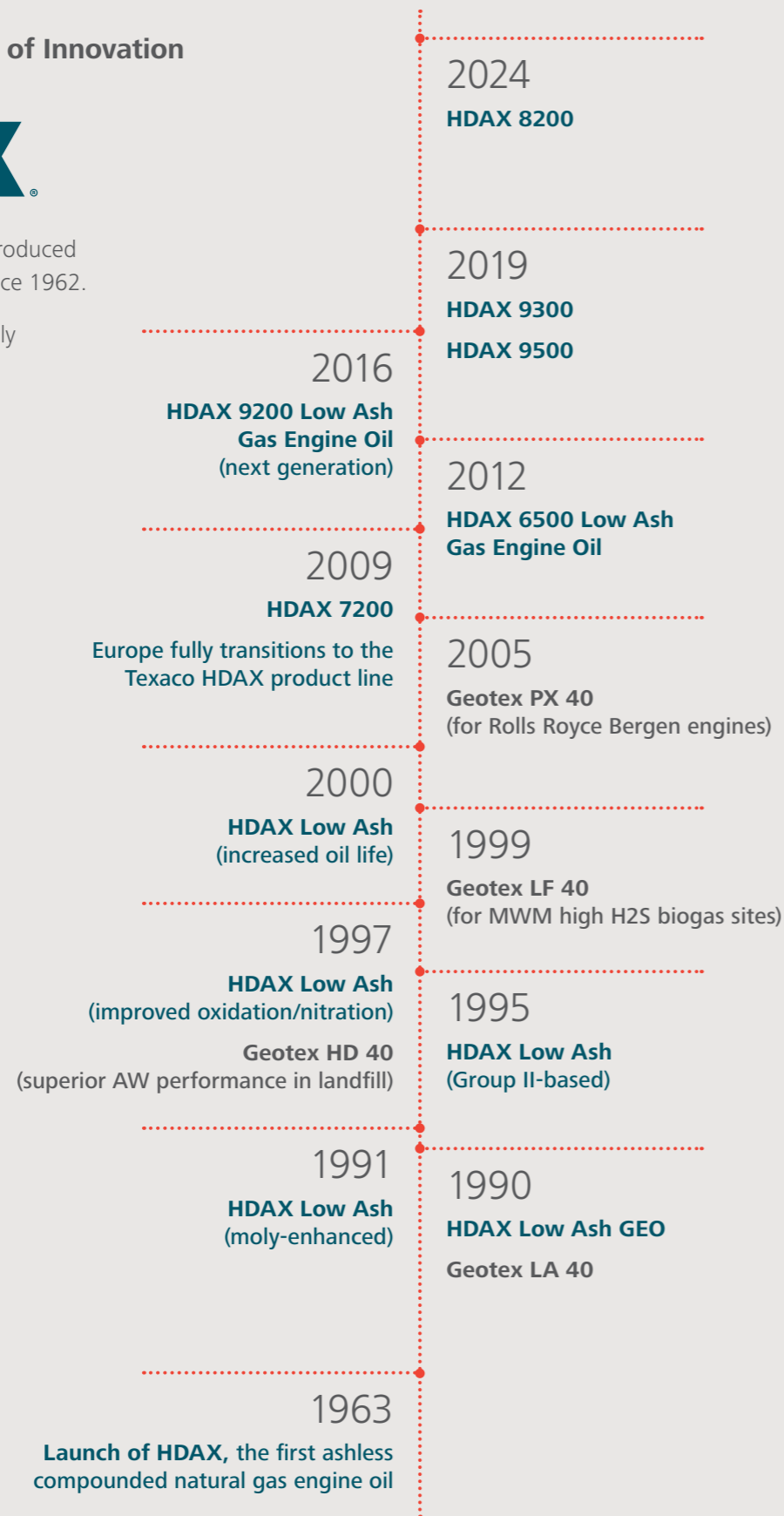

▲ Our focus helps drive your performance

Advancements in technology and tighter emission regulations are placing new demands on power generation lubricants, as they must be able to operate under more extreme conditions and protect increasingly complex and sophisticated equipment.

With Texaco® HDAX®, we are setting new standards in gas engine oil technology, helping you reduce operating costs, optimise maintenance cycles and sustainably increase the overall performance of your engines, without losing sight of the essentials – the profitability of your systems.

We understand the challenges facing the power generation industry today:

- > Rapid transformation within the sector
- > More complex and sophisticated equipment
- > Characteristics of biogas and variations in the quality of the fuel
- > Increasingly strict anti-pollution standards
- > Longer operating hours and heavier loads
- > Extreme temperatures and dirty conditions.

Our Texaco advanced technology gas engine lubricants are formulated to handle tighter equipment tolerances and deliver high-level protection, helping to maximise the life of your equipment, improve running costs and reduce downtime.

Reliability and durability are our priority

Texaco Lubricants stands for one thing above all else – reliability. Properly lubricating the inside of a gas engine requires more than just creating a protective film. HDAX gas engine oils help control nitration, oxidation, acids and other deposits that attack pistons, cylinders and valves, causing poor performance and even catastrophic shutdowns.

Additionally, Texaco HDAX products deliver integrity and performance as proven by various field test results. Texaco’s industry-leading lubricants have logged countless hours providing protection to the key components in gas engines. In addition, our family of gas engine products can also be used for Oil and Gas Gathering and Processing applications.



Texaco HDAX:

Proven protection for your engine

Texaco® HDAX® gas engine oils help keep you protected, so you can reach higher levels of efficiency, optimise performance over the long run and help your engines deliver to their full potential.

Gas engine oils for landfill & biogas applications

Advanced technology HDAX engine oils, specifically designed to protect four-stroke gas engines running on landfill or digester gas from the corrosive effects of acids commonly found in those applications, fuels containing elevated levels of chlorofluorocarbons (CFCs) and/or siloxane, and sour gas applications, where corrosive wear is a particular concern.

HDAX 9500 SAE 40

Latest technology oxidation/nitration resistant gas engine oil with enhanced base number retention characteristics, offering low oil consumption and extended drain intervals.

Designed specifically for high-output 4-cycle gas engines running on landfill gas, biogas and digester gas, and for sour gas applications.

Benefits:

Offers piston deposit control, helping provide cylinder liner scuff and abrasive wear protection, and longer engine service life

Helps minimise oil thickening, sludge formation and filter plugging

Formulated with optimised ash level for valve recession control and helps prevent potential pre-ignition

Designed for optimum protection against corrosion caused by acidic condensate in intermittent operations in sour gas applications

Low phosphorus additive formulation for use with catalyst systems

Also suitable for engines fuelled by landfill gas containing elevated levels of chlorofluorocarbons (CFCs) and/or siloxane, and some natural gas applications

HDAX 9500 SAE 40 specification standards include:

Jenbacher	TEDOM
MAN Truck & Bus	

HDAX 6500 LFG Gas Engine Oil SAE 40

Low ash gas engine lubricant, recommended for four-stroke engines fuelled by landfill gas containing elevated levels of chlorofluorocarbons (CFCs), sour gas applications where corrosive wear is a concern and for engines where low ash oils are preferred.

Benefits:

Helps provide valve recession control, low deposit formation and minimises pre-ignition in four-stroke engines running on harsh fuels

Low phosphorus formulation offers advanced catalyst protection

Designed for corrosion control in engines burning high chlorofluorocarbon (CFC) and/or high sulphur fuels where high acidic condensate forms

Offers extended drain performance with strong base retention, as well as oxidation and nitration resistance characteristics, through a combination of premium base fluids and a robust inhibitor package

HDAX 6500 LFG Gas Engine Oil SAE 40 specification standards include:

Caterpillar	MWM
Cummins	TEDOM
Jenbacher	Waukesha
MAN Truck & Bus	



Proven performance with HDAX®

Texaco HDAX 6500 LFG integral in the project to remove waste from the largest unmanaged open dump remaining in Europe

Vinča landfill site in Belgrade, Serbia:

Trigema demonstrate the reliability of Texaco HDAX 6500 LFG to make the Vinča landfill project a reality

The equipment

Stationary gas engines – CAT CG170-20 and 2x 1.5 MW.

The problem

Vinča landfill in Belgrade, Serbia, take in 1,500 tonnes of household waste and 3,000 tonnes of construction waste on a daily basis. However, despite being equivalent in size to 185 association football pitches, the landfill was running out of space to accommodate new waste, which was being delivered daily.

In 2019, the construction of a new landfill site was started, including an incinerator and a waste-to-energy plant, to meet applicable European Union specifications and standards. The new site will process incoming waste to generate heat and electricity.

The solution

As part of a competitive consultation process for the Vinča landfill project, Trigema (part of T-Group Holding) was tasked with proving to its customer the quality, reliability and effectiveness of its Texaco® products, in relation to the Caterpillar engine recommendations being put forward.

Trigema chose to showcase Texaco HDAX 6500 LFG, resulting in positive feedback, and was also able to demonstrate its expertise in managing oil change intervals, engine maintenance savings and capacity to fulfil the lifespan of the engine. As a result, the company's involvement in the Vinča landfill project was secured, with Texaco Lubricants playing a significant factor in their selection for the first-fill.

Texaco HDAX 6500 LFG has now been implemented into two stationary gas engines that will be used as part of the project.



Gas engine oils for natural gas applications

Our range of HDAX® gas engine oils are formulated for natural gas applications, including those in demanding cogeneration environments where extreme pressures and temperatures can be four-times higher than those in a diesel vehicle engine.

HDAX 9300 SAE 40

Modern technology gas engine lubricant, designed to work within the extreme temperatures and low oil consumption of the latest high BMEP engines.

Helps protect gas engines running on natural gas under heavily loaded conditions, including high output engines in the 10 MWeI class.

Benefits:

Specifically designed to protect engines operating under heavily loaded conditions, including the most modern steel piston engines with BMEP ≥22 bar

Oxidation/nitration resistance with base number retention offers extended drain in very low oil feed rate engines

Offers robust protection against corrosion, harmful deposits and sludge formation

Formulated to optimise ash levels for reliable valve recession control and help prevent potential pre-ignition

Low phosphorus additive design allows use with catalyst systems

HDAX 9300 SAE 40 specification standards include:

Bergen Engines	MWM
Jenbacher	

HDAX 9200 Low Ash Gas Engine Oil SAE 40

Advanced technology lubricant for natural gas applications, designed for the latest high output, turbocharged, low emission gas engines that require a low ash oil.

Offers robust component protection, even under heavy loads, and meets the more demanding needs of high speed 4-cycle gas engines in cogeneration applications.

Benefits:

Designed to resist sludge formation, filter plugging and cylinder liner honing pattern glazing, helping optimise oil flow and consumption

Helps minimise valve recession, combustion chamber deposits and ash build up, reducing potential for pre-ignition

Oxidation and nitration resistance with base number (TBN 4.2) retention, offers extended drain in very low oil feed rate engines

Low phosphorus additive system, suitable for use with most catalyst systems

HDAX 9200 Low Ash Gas Engine Oil SAE 40 specification standards include:

Caterpillar	RMB/Energie
Jenbacher	TEDOM
MWM	Waukesha

HDAX 8200 SAE 40

Extended drain gas engine oil, designed specifically for natural gas engine applications, particularly those in cogeneration environments.

Formulated to offer enhanced drain intervals and reduced oil usage, due to good oxidation/nitration resistance and base number retention.

Benefits:

Meets the more demanding needs of high speed 4-cycle gas engines in cogeneration applications

Advanced low ash additive system helps reduce valve recession and lower pre-ignition risks

Helps reduce maintenance requirements through effective deposit, sludge and wear control, along with corrosion prevention

Suitable for use with fuels containing low levels of sulphur and chlorofluorocarbons (CFCs)

Formulated to meet catalyst compatibility requirements

HDAX 8200 SAE 40 specification standards include:

Bergen Engines	MTU
Caterpillar	MWM
Jenbacher	

HDAX 7200 Low Ash Gas Engine Oil SAE 40

Low ash, bright stock-free dispersant/detergent type gas engine oil, for natural gas and synthetic gas applications.

Recommended for lean-burn and stoichiometric four-stroke engines operating under high load, and high-speed four-stroke gas engines used in cogeneration applications.

Benefits:

Offers reliable oxidation and nitration resistance to help reduce the build-up of insolubles and promote long oil and filter life

Advanced additive technologies aid reduced valve recession, combustion chamber deposits, pre-ignition and spark plug fouling

Formulated to meet NSCR catalyst compatibility requirements and suitable for installations requiring low phosphorus oil to help prevent exhaust catalyst poisoning

HDAX 7200 Low Ash Gas Engine Oil SAE 40 specification standards include:

Caterpillar	MWM
Bergen Engines	Superior
Deutz	Wärtsilä
Dresser-Rand	Waukesha
Jenbacher	Worthington
MTU	

HDAX 5200 Low Ash Gas Engine Oil SAE 30, 40

Low ash gas engine oils for four-stroke, and selected two-stroke, stationary engines fuelled by natural or synthetic gas.

Benefits:

Bright stock-free formulation with premium base oil technology

Formulated to meet NSCR catalyst compatibility requirements, especially for installations requiring low phosphorus oil to prevent exhaust catalyst poisoning

Promotes sludge minimisation and keep-clean performance in the crankcase, valve rocker cover and in top deck areas

Offers reduced maintenance downtime, lower maintenance costs and longer engine service life

HDAX 5200 Low Ash Gas Engine Oil SAE 30, 40 specification standards include:

Caterpillar	MWM
Delaval Enterprise	Superior
Deutz	TEDOM
Dresser-Rand	Wärtsilä
Everlence/MAN Energy Solutions	Waukesha
Jenbacher	Worthington

▲ Texaco premium greases

Texaco® grease products are formulated to provide high performance and longlife protection in adverse climates and tough operating environments.



Marfak Bio EliteSyn HD 2

Anhydrous calcium thickened grease suitable for lubrication of heavily loaded bearings, even at low temperatures. Promotes good component wear, corrosion and rust protection, offering long system performance and service life.

Formulated with biodegradable synthetic esters for environmentally acceptable lubrication (EAL).

Marfak Bio EliteSyn HD 2 specification standards include:

DIN / ISO	VIDA / VGP 2013
Swedish Standard (RISE listing)	

Black Pearl SRI 2

High temperature polyurea ball and roller grease, for use in antifriction bearings operating at high speeds (10,000 rpm and greater).

Designed to help protect bearings across a wide temperature range (-30°C to 177°C).

Black Pearl SRI 2 specification standards include:

DIN / ISO

Texaco gas engine oils, coolants and ancillary products for natural gas and biogas power generation equipment

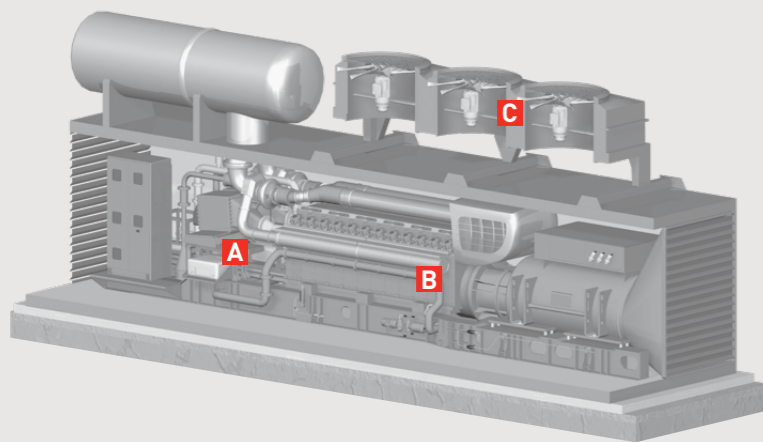

Engine (landfill and biogas)

HDAX 9500	Power Generation	4-cycle	A
HDAX 6500	Power Generation	4-cycle	A

Engine (natural gas)

HDAX 9300	Power Generation	4-cycle	A
HDAX 9200	Power Generation	4-cycle	A
HDAX 8200	Power Generation	4-cycle	A
HDAX 7200	Power Generation and Oil & Gas	4-cycle	A
HDAX 5200	Power Generation and Oil & Gas	4-cycle	A

Cooling system

Delo XLC Antifreeze/Coolant Concentrate, Premixed 40/60	B
Delo XLI Corrosion Inhibitor Concentrate	B
EGN Antifreeze/Coolant Concentrate, Premixed 50/50	B
EGX Antifreeze/Coolant Concentrate, Premixed 50/50, Premixed 40/60	B

Cooling fans

Black Pearl SRI 2	C
Marfak Bio EliteSyn HD 2	C

▲ Texaco silicate-free coolants

Designed to offer low service maintenance service life and long-term protection from the extreme pressures and temperatures produced by gas engines.



Delo XLC Antifreeze/Coolant Concentrate, Premixed 40/60

Ethylene glycol-based antifreeze/coolants, recommended for improved heat transfer performance, cavitation protection and longlife cooling system protection.

Benefits:

Formulated for long, low maintenance service life
Offers up to 32,000 hours in stationary engines
Promotes reliability and corrosion protection
Contributes to reliable hard water stability
Aids high temperature corrosion protection

Delo XLC Antifreeze/Coolant Concentrate, Premixed 40/60 specification standards include:

ASTM	MTU
Cummins	MWM
Deutz	TEDOM
Jenbacher	Wärtsilä
MaK	

EGX Antifreeze/Coolant Concentrate, Premixed 50/50, Premixed 40/60

OAT-based coolants, designed to provide boil protection in the most extreme conditions and advanced heat transfer performance throughout fluid lifetime.

EGX Antifreeze/Coolant is free of 2-EHA, nitrite and borate.

Benefits:

Advanced heat transfer performance
Longlife OAT-backed performance
Good high temperature oxidation and pH stability
Neutralisation package helps prevent gels or deposits

EGX Antifreeze/Coolant Concentrate, Premixed 50/50, Premixed 40/60 specification standards include:

CLAAS	John Deere
Detroit Diesel	Perkins
Deutz	UNE
Jenbacher	Voith

EGN Antifreeze/Coolant Concentrate, Premixed 50/50

Antifreeze/Coolants formulated with Nitrited Organic Additive Technology (N-OAT), for protection in the most extreme conditions in on- and off-road heavy-duty, stationary and natural gas engine applications.

Benefits:

Free of 2-EHA and borate
Advanced heat transfer performance throughout fluid lifetime
Compatible with CAB brazed aluminium heat exchangers
Designed to help avoid adverse effect of flux material used during the production process

EGN Antifreeze/Coolant Concentrate, Premixed 50/50 specification standards include:

ASTM	Cummins
China National Standard	

Delo XLI Corrosion Inhibitor Concentrate

Extended life corrosion inhibitor, formulated with advanced non-depleting inhibitor technology.

Benefits:

Extended low maintenance service life
Formulated to protect vulnerable components
Effective hard water stability
Designed to provide high temperature aluminium corrosion resistance

Delo XLI Corrosion Inhibitor Concentrate specification standards include:

Everlence/MAN Energy Solutions	MTU
Jenbacher	MWM
MaK	Wärtsilä



texacolubricants.com/HDAX

▲ Texaco: with you for the long haul

Texaco® HDAX® products with OEM approvals are supported by our in-house expertise, robust in-field testing and backed-up by detailed value-driven oil analysis, Texaco Lubewatch, to ensure they can meet the ever-changing needs of the power generation sector.

Expert field teams

Texaco's lubrication expertise, combined with high quality products and a tailored service programme, work together to help your business. Specialists who understand natural gas engine equipment can conduct an assessment of your current lubrication programme to help identify areas for improved performance compared to industry-best peers.

Protection you can rely on

We have a history of heavily investing in research and development to ensure your machinery gets the utmost protection. We're so confident about the quality of our products, that we offer the 'Texaco Limited Product Warranty' on all Texaco lubricants, coolants, grease products and aftermarket fuel additives.



LubeWatch used oil and coolant analysis

Today's gas engines often operate under demanding conditions, encountering high temperatures, heavy loads and contaminant exposure. As such, without adequate lubrication, these stresses lead to increased friction, accelerated wear and potential equipment failure.

That's why our LubeWatch Oil Analysis programme offers a simple and effective way to track the performance of equipment. By analysing oil samples on a regular basis, you can help optimise oil replacement intervals, identify lubricant-related needs and understand the changing environment within a piece of equipment. This knowledge helps in the precise scheduling of maintenance work that can reduce downtime or even eliminate the risk of catastrophic failure.

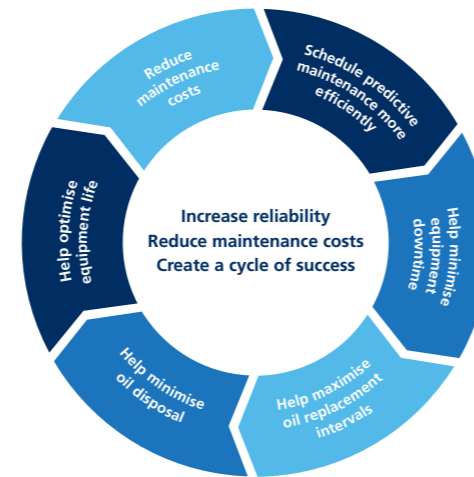

LubeWatch® Oil Analysis Program

To find out more about how our products and services can assist you, contact your Texaco Representative, your Authorised Texaco Lubricants Distributor or visit [texacolubricants.com/HDAX](https://www.texacolubricants.com/HDAX)

Texaco® HDAX®
enduring performance



Advanced technology Texaco® gas engine lubricants & coolants.

Whatever the lubricant requirement – private and commercial vehicles through to industrial plant and machinery operating in some of the world’s most challenging environments – customers trust Texaco.



Scan to find out more.

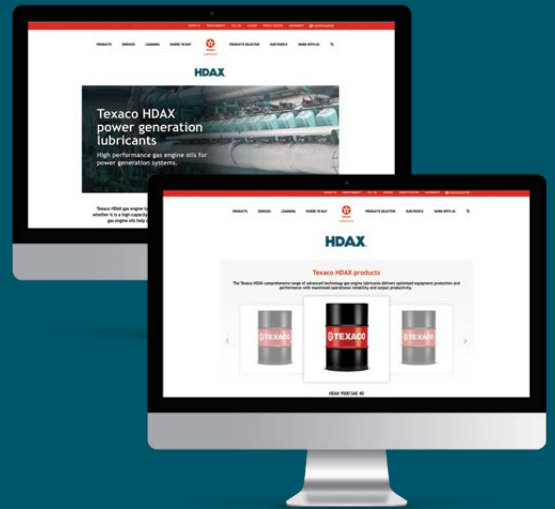

Chevron's Family of Brands

A Chevron company product

texacolubricants.com/HDAX